



MULTIDUST® BANK

Filtration units tailored
to your needs



MODULAR FILTERS

The MultiDust®Bank filter is a modular filter system which can be tailored to the requirements of your application today and expanded tomorrow if your business grows. In addition, the efficient and effective performance of each module allows for a compact solution. The range of technical features and the latest filter technology adds up to a filter system which is cost effective to operate and maintain.

WHY FUME EXTRACTION IS IMPORTANT

Welding fumes, grinding dust, oil mist: the metal industry produces all sorts of contamination. Welders and personnel in working areas are exposed to these air contaminants. It is essential to create healthy and safe working conditions by reducing these risks. Protective measures are an important aspect of this. So important, in fact, that strict international standards have been established to regulate them. Welding fumes, small particles and the airborne remains of molten metal must be dealt with effectively by means of professional extraction and filtration. This ensures that workers feel better, enabling them to perform better. The result is higher productivity and lower absenteeism through sickness.

LOW COST OF OWNERSHIP

The Ram-Air cleaning system ensures a clean filter. Inside every filter cartridge a Ram-Air pulse disperses the compressed air for cleaning, releasing any dust collected on the surface of the filter cartridge. This gives longer filter life and less expensive compressed air usage, all resulting in low cost of ownership.

FLEXIBLE INLET & OUTLET

The MultiFlow multiposition inlet can be fitted in a variety of positions depending on size, concentration of particles and space requirements. The inlet can be supplied in various sizes to fit the relevant duct. The outlet can be positioned on any of the four sides of the MultiDust®Bank filter. Available in various sizes to fit the relevant connecting duct.

SAFETY

In applications where hot sparks might be a risk of damage or fire, an optional slide-in pre-filter can be positioned in the inlet.

EFFICIENT FILTRATION

The high filtration efficiency can allow re-circulation of cleaned air as well as energy savings through heat recovery. The unique MultiFlow air shield disperses incoming air evenly, resulting in equal air flow throughout multiple modules.

MODULAR DESIGN

The modular MultiDust®Bank allows for any size solution, fitting your requirements and give optimum cost efficiency. Moreover it is flexible to expand as your business and your workload grow.

PLUG & PLAY

The MultiDust®Bank is available in two Plug & Play versions: MDB-2-F and MDB-4-F. These filter units are equipped with fan and controls. They are very simple to install, just connect the duct work, power supply and compressed air and you are ready to go.

Quality from top to bottom



Inlets and outlets can be mounted in a variety of side and top positions for maximum flexibility of ductwork installation. Several sizes are available as well.



Ram-Air Balancing Diffuser distributes the compressed air, for optimal cleaning and reduced compressed air consumption.

The leg rack is made of galvanized steel with open profiles preventing rust.

Dustbin with handle and connection lift ensures no leakage and ease of operation.

BENEFITS

- Efficient filtration of dust and fumes
- Modular design for any size solution
- Flexible positioning of inlet and outlet
- Expandable when your business grows
- Low cost of ownership



HOW IT WORKS

1. Polluted air passes through the MultiFlow inlet to the filter.
2. Highly efficient filter cartridges clean the air.
3. A MultiFlow outlet is fitted to the clean air side.
4. Filter cleaning is performed by efficient compressed air pulses using Ram-Air technology, cleaning the entire cartridge.
5. The outlet at the bottom of the hopper allows dust removal.

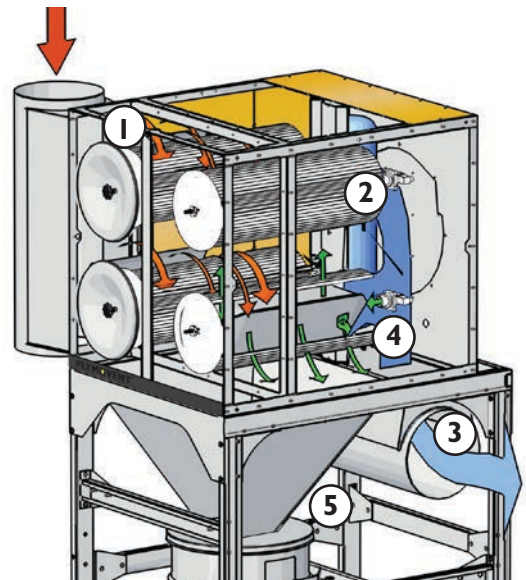

Technical specifications

Example of system configurations

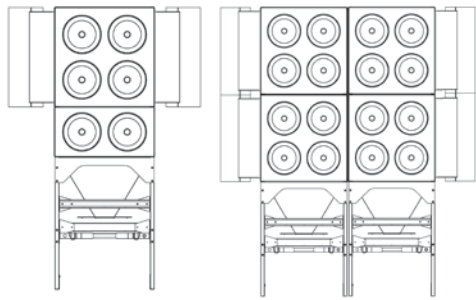

Plug & Play MDB-4F

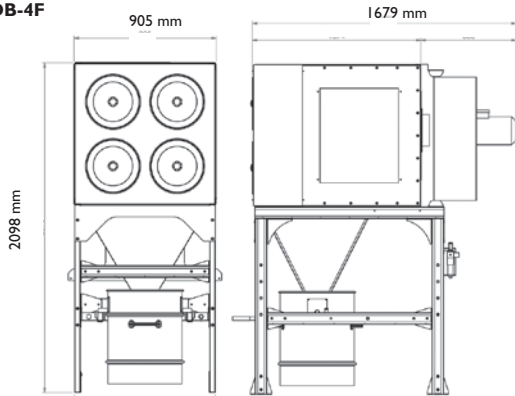

Plug & Play MDB-2F

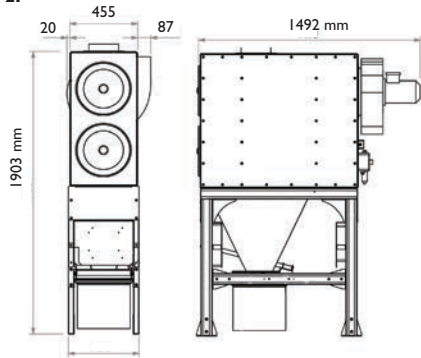

- Available from 2 to 64 cartridges in one system
- **Dimensions:** Depending on configuration - check product data sheet for more information
- **Filter surface area per cartridge:** standard 15 m², others on request
- **Filter efficiency:** (class M)

Plug & Play

MDB-2-F

Dimensions (L x W x H):
1492x562x1903 mm
Connection voltage:
400V / 50 Hz, 460V / 60 Hz
Power: 1.1 kW
Weight: 210 kg

MDB-4-F

Dimensions (L x W x H):
1679x905x2098 mm
Connection voltage: 380-460 V / 50-60 Hz
Power: 2.2 kW
Weight: 339 kg

COMPLETE SYSTEM

The MultiDust[®]Bank can be connected to our product range of extraction arms, downdraft tables, extraction hoods, fans and control equipment. Our systems enables you to get fully automatic control of our products in the most efficient way, saving you money and bringing you clean air at work.



Welding Company NV Belgium
Brandekensweg 6 - 2627 Schelle
Tel.: +32 3 880 81 80
info@weldingcompany.be

Welding Company Nederland BV
Ambachtsweg 2 - 4128 LC Lexmond
Tel. +31 (0)347-745008
info@weldingcompany.nl

Your authorised Plymovent distributor: